

- NOTES:
- A. FOR REFERENCE ONLY UNLESS PROPERLY ENDORSED. FOR ADDITIONAL DETAILS AND SPECIFICATIONS, CONSULT FACTORY.
 - B. DIMENSIONS ARE IN INCHES [MILLIMETERS].
 - C. HATCHED AREA INDICATES PERMISSIBLE CONDUIT ENTRANCE AREA.
 - D. FANS, FILTERS, LEG STANDS OR CLOSING PLATES ARE SUPPLIED WHEN OPTION MIX NECESSITATES.
 - E. USE APPROPRIATE TYPE RATED HUBS OR FITTINGS TO MAINTAIN ENCLOSURE RATING.

chuck_powell Tuesday, April 03, 2018 2:50:05 PM

YASKAWA

DRAWN: D. Packer	DATE 07/01/2012
CHECKED: D. Cmelak	DATE 07/01/2012
TECH:	DATE
APPROVED: K. Flierl	DATE 07/01/2012
ORIGINAL DESIGN: D. Packer	DATE 07/01/2012

TITLE: DIMENSION DRAWING, A & P 1000, TYPE 3R, W4		
MATERIAL# ---		
SIZE A	REVISION 04	PAGE 1 OF 2
DRAWING #: DD.AP1.3R.W4.01		

THIS DOCUMENT AND INFORMATION CONTAINED IN IT ARE CONFIDENTIAL, AND CANNOT BE COPIED OR DISCLOSED IN WHOLE OR IN PART WITHOUT THE EXPRESS WRITTEN CONSENT OF YASKAWA AMERICA INC.

REVISIONS

REV.	DESCRIPTION	ECO #	DRAWN BY	DATE
04	PAGE 2: UPDATED DIMENSIONS.	8530	C.AP	3/22/2018
03	DIMENSIONS CORRECTED.	6641	DSD	5/10/2016

LEG STAND MOUNTING OPTION DIMENSIONS

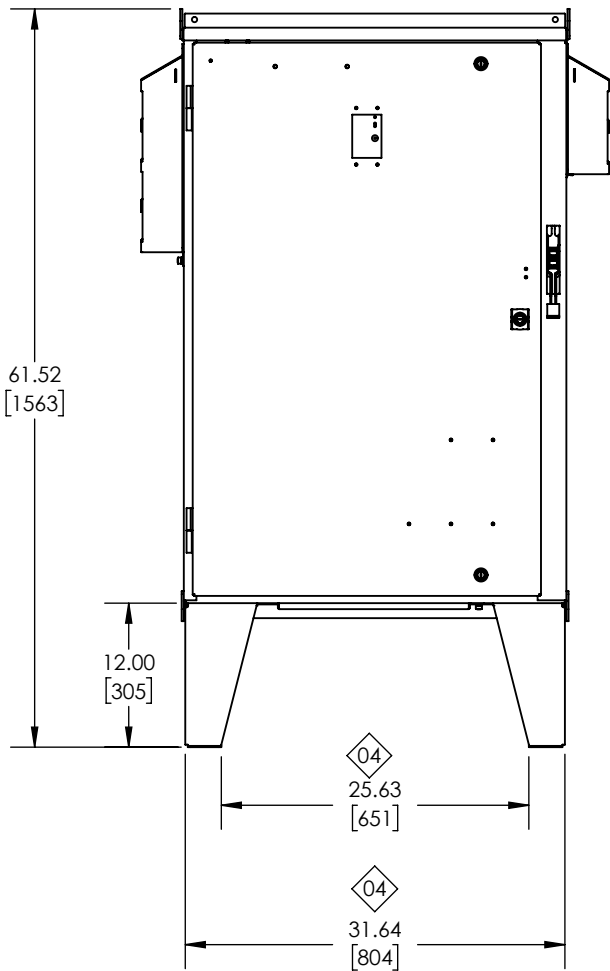

12.0" HIGH LEGS

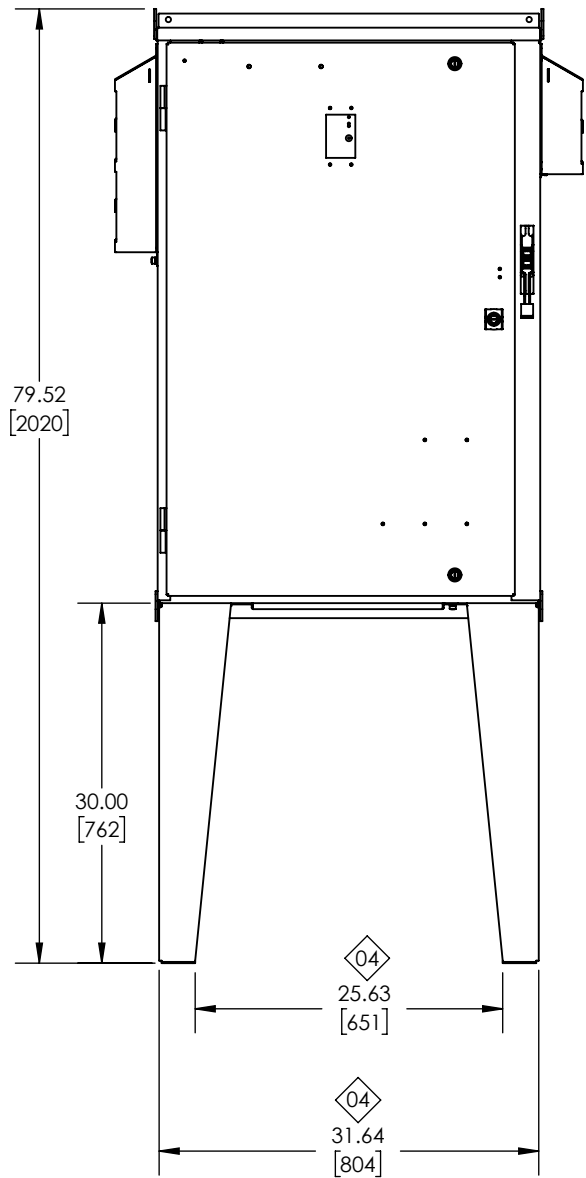

30.0" HIGH LEGS

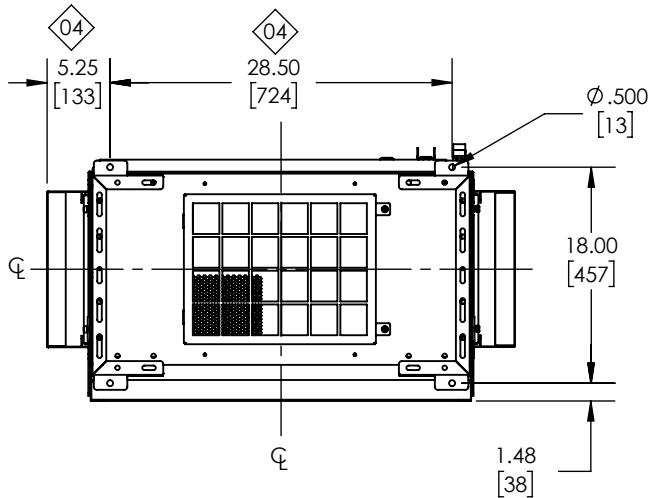

NOTE: DRILL PATTERN SAME FOR 12" AND 30" HIGH LEGS

chuck_powell Tuesday, April 03, 2018 2:50:05 PM

 <p><i>THIS DOCUMENT AND INFORMATION CONTAINED IN IT ARE CONFIDENTIAL, AND CANNOT BE COPIED OR DISCLOSED IN WHOLE OR IN PART WITHOUT THE EXPRESS WRITTEN CONSENT OF YASKAWA AMERICA INC.</i></p>	DRAWN: D. Packer	DATE 07/01/2012	TITLE: DIMENSION DRAWING, A & P 1000, TYPE 3R, W4			
	CHECKED: D. Cmelak	DATE 07/01/2012				
	TECH:	DATE	MATERIAL#	---	---	---
	APPROVED: K. Flierl	DATE 07/01/2012	SIZE A	REVISION 04	PAGE 2 OF 2	
ORIGINAL DESIGN: D. Packer	DATE 07/01/2012	DRAWING #: DD.AP1.3R.W4.01				